

WinCamD™-THz

Slim, Affordable, High Resolution 3 - 20 THz Multispectral Imaging

With large active area, high spatial resolution, global shutter, and fast frame rate, the port-powered **WinCamD™-THz** is ideally suited to multispectral THz laser beam profiling.

The slim, compact package with flexible USB 3.0 cable easily inserts into tight optical trains. Unlike bolometric & pyroelectric alternatives, the camera is insensitive to background thermal noise.

Switchable software configurations allow the user to move swiftly between multi-spectral alignment mode and a mode which compensates for the non-linear response to THz beams. Shutter trigger options simplify single or multi-shot pulse capture. The camera is paired with DataRay's full-featured software which has no license fees, unlimited installations, comprehensive interfacing options and free software updates.



Shown actual size
1.8 x 1.8 x 0.8" 46 x 46 x 20 mm

System Features

- 3 - 20 THz (15 to 100 μm) **plus** 350 - 1150 nm
- 2048 x 2048 pixels, 11.3 x 11.3 mm active area
- 5.5 μm pixels
- 12 fps @2048 x 2048 to 60 fps @512 x 512
- Port-powered, USB 3.0; flexible 3 m cable
- HyperCal™** - dynamic noise & baseline correction
- Real-time non-linearity correction
- Global electronic shutter, 85 μs to 2 s
- TTL, optical, and auto-trigger options
- 12-bit ADC
- Parallel capture on multiple cameras
- Field-replaceable image sensors
- Relative power level display

Applications

- THz laser **profiling/alignment**
- Non-linear pump-probe spectroscopy**
- Medical & security inspection/QA** of opaque objects
- Field servicing** of THz lasers & laser-based systems

Power/Energy Range

- Saturation:** Single pulse, $\tau \approx 1$ ps [proportional to $(\tau)^{0.25}$]
 - ~ 100 mJ/cm² @ 3 THz
 - ~ 15 mJ/cm² @ 6 THz
 - ~ 5 mJ/cm² @ 10 THz

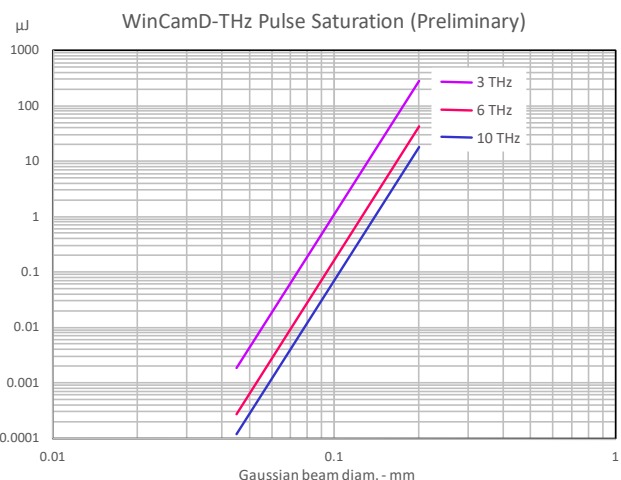
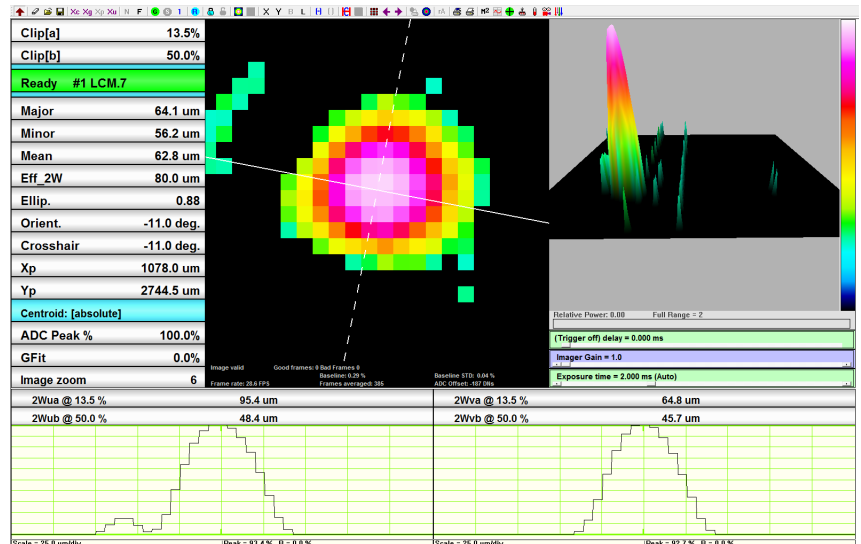
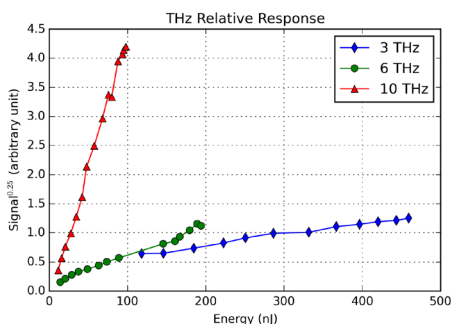

Acknowledgements: Measurements carried out and provided by Mostafa Shalaby, Carlo Vicario & Christoph P. Hauri, SwissFEL laser group, Paul Scherrer Institute, Villigen, Switzerland

Windows/Spectral Filters/Attenuators

The camera sensor is supplied window-free with ND filters for 350-1150 nm use. Contact the factory for advice on sources of windows, spectral filters and attenuators.

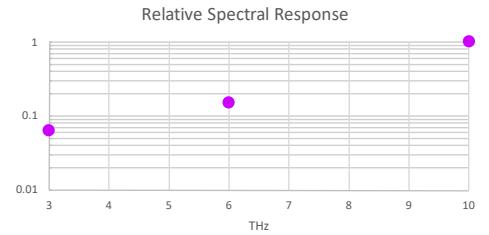

Software Features

- XY profiles and centroids
- Linear and logarithmic displays
- Gaussian and Top Hat least squares fits
- Ellipse angle, major, minor, mean diameters
- Background capture and subtraction
- Image & intensity zoom
- Linear and area filters
- Image averaging, 1 to continuous
- Proprietary HyperCal™ dynamic noise and baseline correction

WinCamD-THz Specifications (Subject to change without notice):

Pixel size, H x V & Count:	5.5 x 5.5 μm pixels, 2048 x 2048, 4.2 MPixel		
Sensor image area:	11.3 x 11.3 mm		
Shutter type:	Global		
Frame rate:	≥ 60 Hz @ 512 x 512; ≥ 30 Hz @ 1024 x 1024; ≥ 12 Hz @ 2048 x 2048		
Max. 'every pulse' PRR:	≥ 12.5 Hz		
Single pulse capture max PRR:	USB 3.0: 12.6 kHz; USB 2.0: 6.3 kHz		
Signal to RMS Noise:	$>500:1$		
Electronic Shutter:	25,000:1, 85 μs to 2s on USB 3.0; 12,500:1 158 μs to 2s on USB 2.0		
ADC:	12 bit		
Interface:	USB 3.0 Port-powered		

Outline & Mounting (shown actual size)

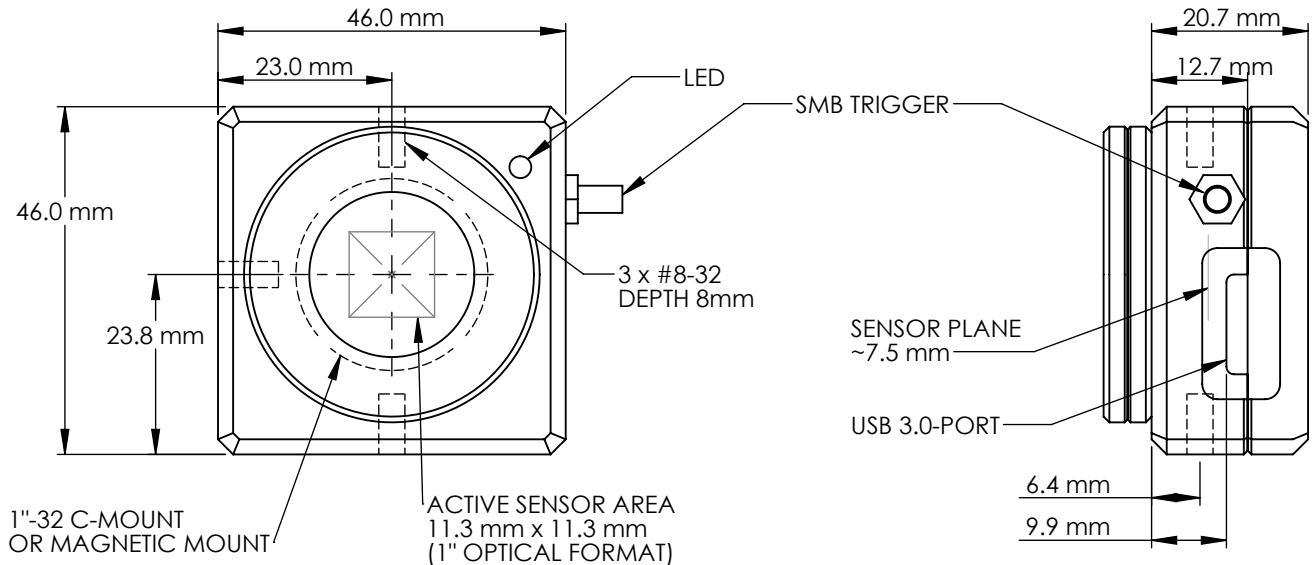

Ordering Information

Model #	Description
S-WCD-THz	Complete WinCamD-THz system with USB 3.0 cable, manual and software

Founded in 1988, DataRay Inc. is the worldwide leader in beam profiling and analysis, delivering innovative, high-quality, affordable, and reliable instrumentation to the photonics industry. Product lines include beam profiling cameras (190 nm to 14 μm , & 3-20 THz), and scanning slit beam profilers (190 nm to 3.9 μm , model-dependent).