

# SpotOn Mobile

Positioning System with  
Nexus7 Tablet-PC

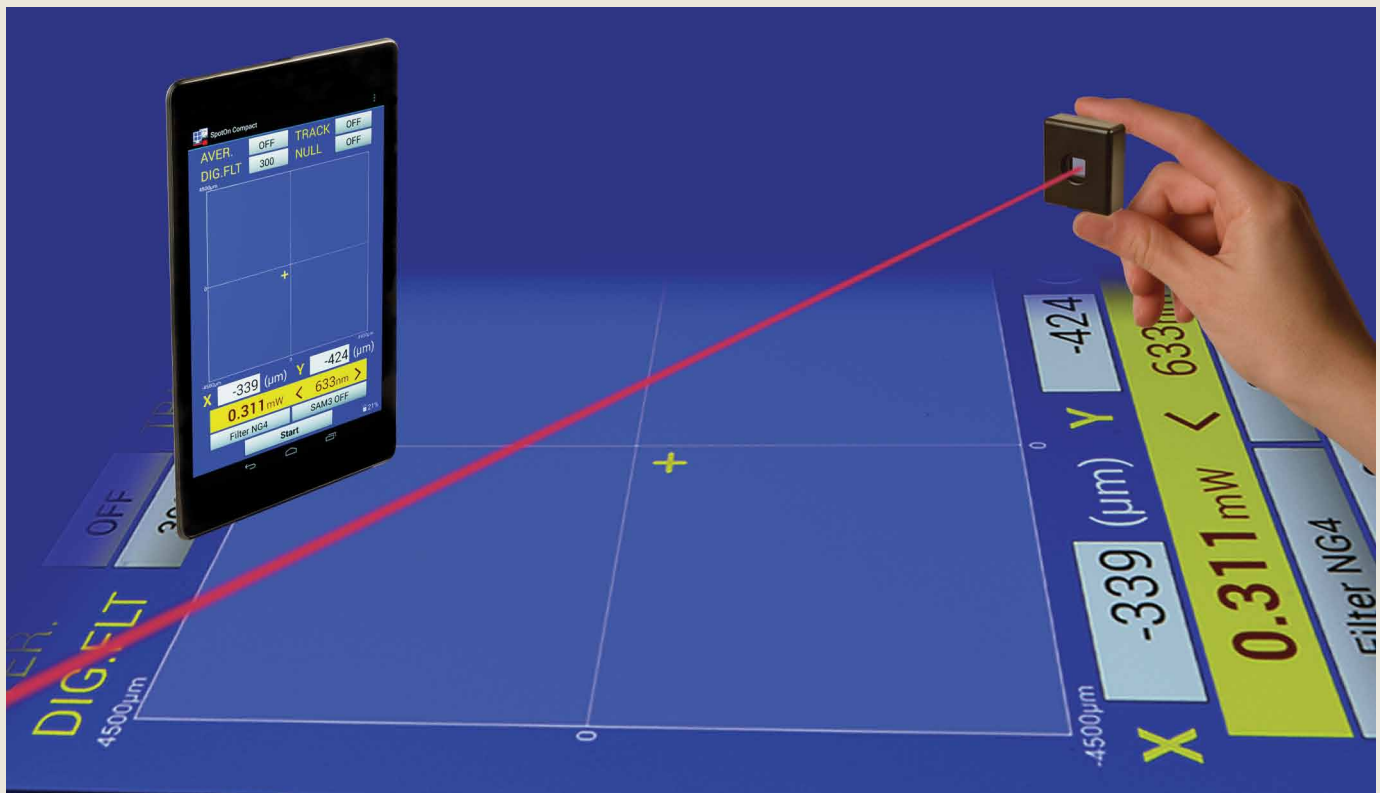

## *A cost-effective, positioning system*

- **Versatile:** Measures both Beam Position (over area up to 9mm diameter) and power (from 1 $\mu$ W to 2.5mW @ 633nm without filters)
- **Precise:** Available with dual axis Lateral Effect detector (down to 1 $\mu$ m resolution @ 50Hz digital filter,  $\pm$ 6 $\mu$ m absolute accuracy)
- **Convenient:** Stand Alone unit including detector head and Tablet-PC
- **Easy to use:** User friendly software, with touch screen interface
- **Compact:** Built-in electronics within sensor head

## *Key Features*

- Convenient automatic Gain setting
- New hardware having 24 bit A/D
- Real time display of Position and Power measurements
- Direct data logging to Excel format files
- Up to 5 hours operation on device battery only
- High power version available (with SAM3-HP)
- Software Main functions:  
Average Digital filter, Null, Track-Log file, Trace On / Off, Filter selection, SAM3 setting.

## *Main Applications*

- **Specially adapted for field service of laser measurements.**
- Measure CW laser power and centration or displacement
- Align beams and quality control optical systems
- Measure target rotation and displacement
- Calibrate surface flatness and machine tool alignment
- Monitor vibration, deflection and motion



**DUMA OPTRONICS LTD.**



**海纳光学有限公司**  
**HIGHLIGHT OPTICS CO., LTD.**

Tel: 0755-84870203    www.highlightoptics.com  
E-mail: sales@highlightoptics.com



# Measurement Specifications

<b>Detector</b>	<b>L – Lateral Effect</b>
Size	9mmx9mm
Type	Dual-axis Si resin No glass cover
Usable beam size	50µm to ø9mm
Position measurement range	∅9mm
Position resolution	Down to 1µm at 50Hz digital filter plus averaging
Position accuracy	±12.5 µm over 9 mm dia.
Update rate	Max 80Hz at 1000Hz digital filter
Operational spectral range	350-1100nm
Power range	1µW to 10 mW with attenuating ND filters
Power accuracy(*)	±5%



\* To maintain full calibration accuracy, attenuating optical filters may be necessary for operation with beams greater than 1 mW. Saturating "non-linear" effects depend on the beam size, type and wavelength, but caution should be exercised when using the PSD above 1-3mW.

## Resolution versus Digital Filter bandwidth

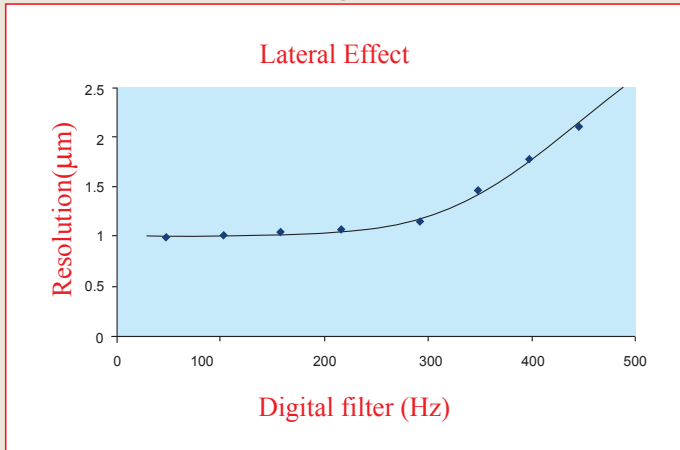

Controls the bandwidth of detector's response, where lower digital Filter attenuates the system noise and increases system's resolution

## Sensor head dimensions

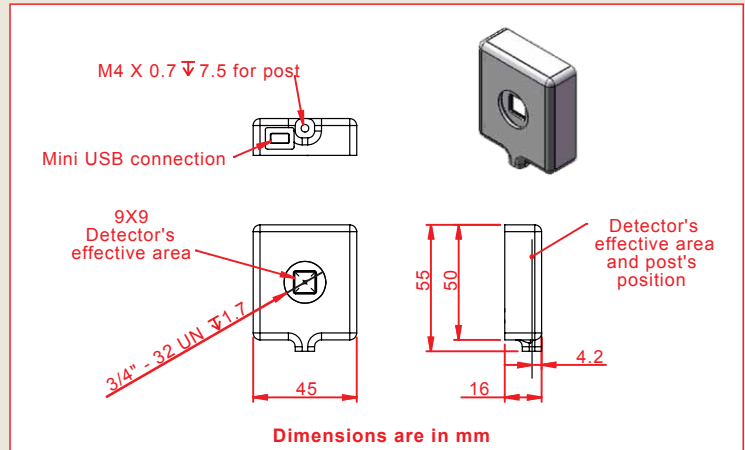

Weight: 60 g



## Ordering information

**SPOTMOB-N** - Complete system including a sensor head, a Nexus7 Tablet PC, Micro USB OTG cable w/Power port, Tablet PC power supply, carrying case.

**SPOTMOB-A** - System for Android 4.1 and up including a sensor head, Micro USB OTG cable, software on DiskOnKey, carrying case.

**SAM3-HP** - Beam sampler for high power lasers

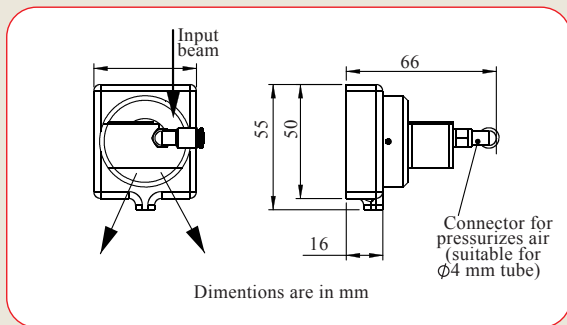

SAM3-HP



## Optional accessories

**NG4/NG9/NG10** – ND filter in housing (3/4" –32 thread)

**Hood** – 55mm long, for ambient light suppression

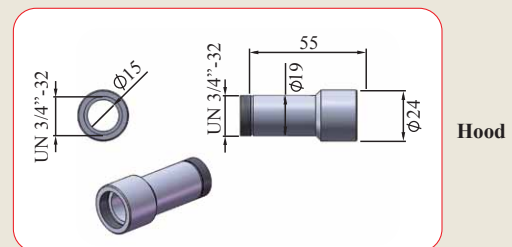
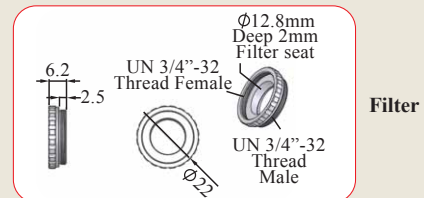

**DUMA OPTRONICS LTD.**



**海纳光学有限公司**  
HIGHLIGHT OPTICS CO., LTD.

Tel: 0755-84870203 www.highlightoptics.com

E-mail: sales@highlightoptics.com