

Scanning Stage SCAN^{plus} IM 120 x 80 for Olympus IX53 / IX73 / IX83

Specifications

Travel range	max. 120 x 80 mm
Max. travel speed	max. 120 mm/s (with 2 mm ball screw pitch)
Repeatability	< 1 µm (bi-directional, measured according to VDI/DGQ 3441)
Accuracy	+/- 1 µm (measured according to VDI/DGQ 3441)
Resolution	0.05 µm (smallest step size)
Orthogonality	< 10 arcsec
Motor	2-phase stepper motor
Limit switches	wear-free Hall sensors
Material / surface	aluminium / anodic coating, black lacquered
Weight	approx. 4,600 g

Order Information

Order No.: 00-24-579-0000
(2 mm ball screw pitch)

Product Features

- ▶ integrated linear measuring systems for highest accuracy
- ▶ flat, ergonomic design with rounded corners
- ▶ plain surface for easy cleaning
- ▶ stationary connecting cables between scanning stage and controller
- ▶ integrated electronic stage identification device ETS for automatic identification of the scanning stage and parametrization of the controller
- ▶ **5 years guarantee**, if the scanning stage is operated in the system with the Märzhäuser TANGO controller

Dimensions

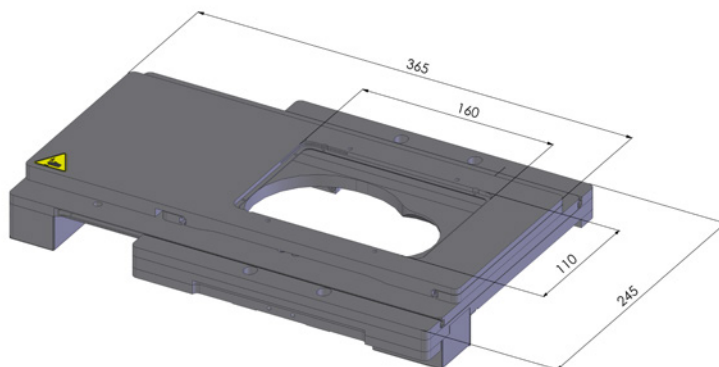

Accessories

Stage insert for 1 slide
3" x 1" (included in delivery)
Order No.: 00-29-411-8010

Piezo Z-stage
Order No.: 00-55-540-0800

Various stage inserts
with dimensions 160 x 110 x 8 mm