



▶ **Manual Measuring Stage MT 25 x 25** for hardness testing

Measuring range:	25 x 25 mm (1" x 1")
Resolution:	depends on the micrometer
Micrometer mount:	∅ 12 mm (other ∅ on request)
Weight:	1.25 kg
Load capacity:	50 kg

Order Information

MT 25 x 25
Order No.: 00-30-223-0000

Product Features

- ▶ for hardness testing
- ▶ various micrometers with a resolution of up to 1 µm are available
- ▶ For mounting the stage, there are 4 holes (M5 thread) in the lower plate. Other hole patterns or special adaptors are available on request.

Dimensions:

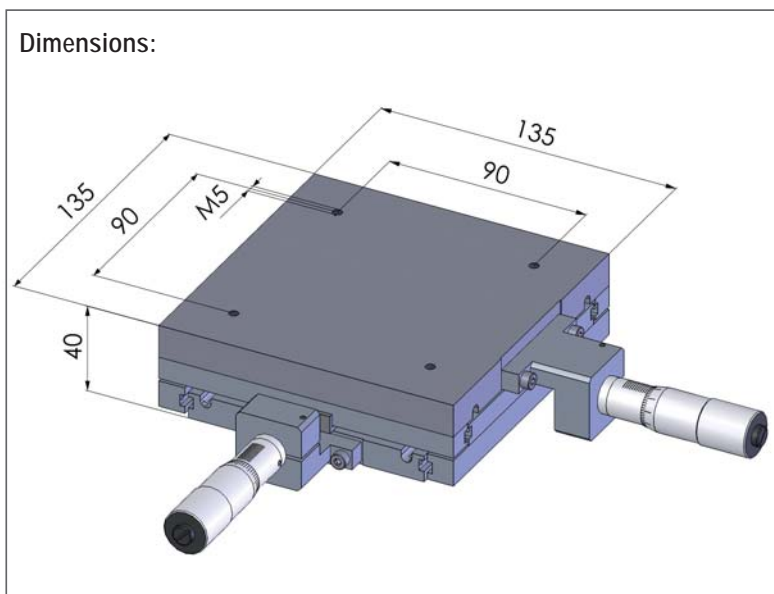

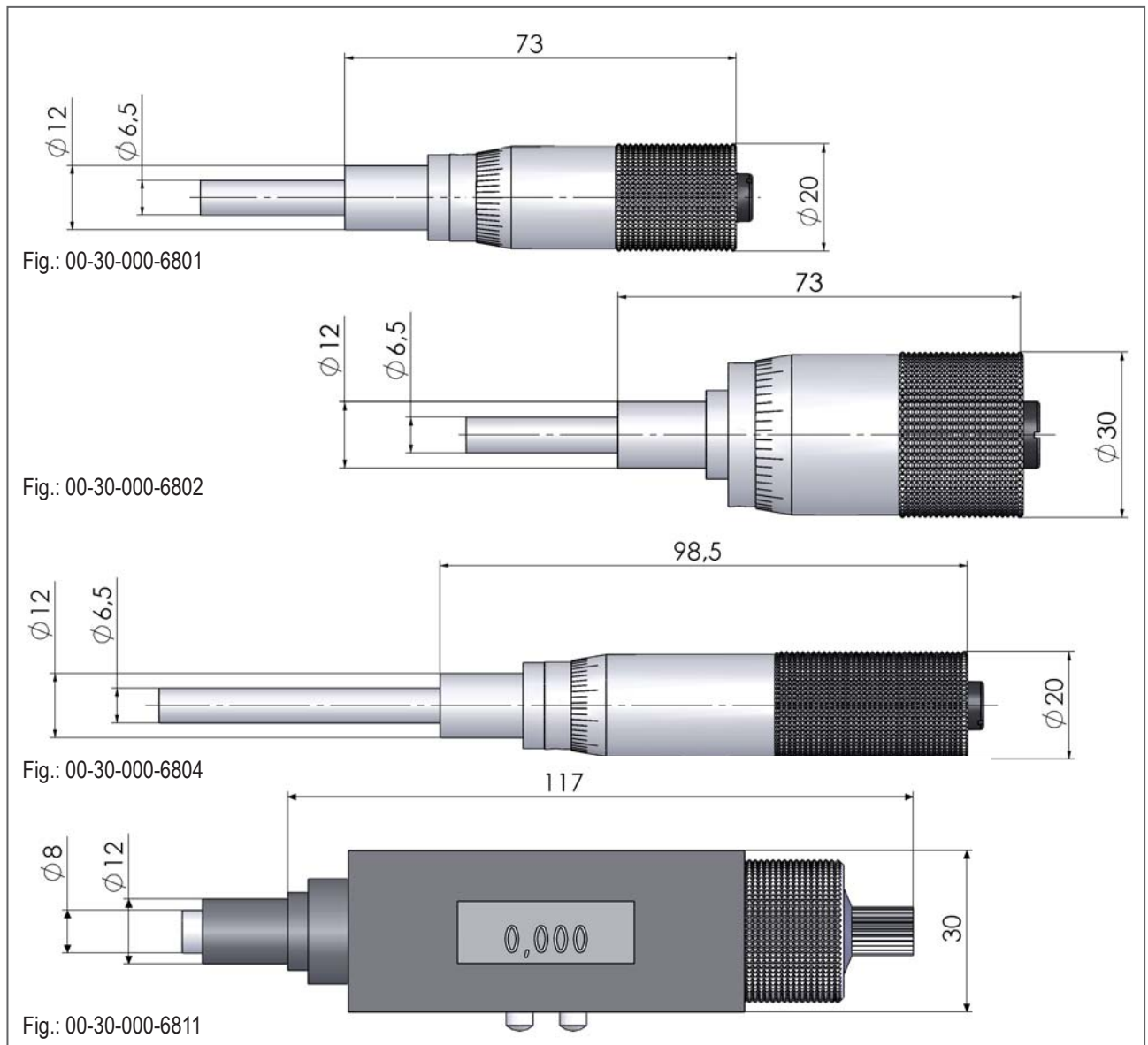

▶ Micrometer Screws for Manual Measuring Stages

Range:	Drum Diameter:	Resolution:	Order No.:
25 mm (analog)	20 mm	10 µm	00-30-000-6801
25 mm (analog)	30 mm	5 µm	00-30-000-6802
50 mm (analog)	20 mm	10 µm	00-30-000-6804
50 mm (analog)	30 mm	5 µm	00-30-000-6805
25 mm (digital)		1 µm	00-30-000-6811
50 mm (digital)		1 µm	00-99-900-1898*

*mounting shaft: 18 mm

Product Features

- ▶ Mounting shaft: Ø 12 mm / 18 mm
- ▶ Lead screw pitch: 0.5 mm
- ▶ Accuracy according to DIN 863-1
- ▶ Threads of ground hardened steel

For accessories please refer to:
www.marzhauser.com