

KEY FEATURES

- Fast Pulsable Source of Black-body Radiation
- Emulates a Black-body in Spectral Distribution
- Ultra-thin Metallic Foil Active Element
- Parabolic Reflector for Collimation and Uniformity
- Fast Pulse Rates, up to 200 Hz with 50% Modulation Depth
- High Output Emitter 0.04 Watts/cm²
- Broadband Output with Typical 0.88 Emissivity
- Hermetic Sapphire Window allowing Emission up to 6 μm

APPLICATIONS

- Gas Analysis, Medical and Industrial
- Environmental Monitoring
- Spectroscopy
- Process Control Systems

The SPF IR emitter is designed to be used as fast pulsed sources of black-body radiation. The design has been optimized for high modulation depth and optical output.

The radiating element in the pulsable emitter is an ultra-thin Opto Diode specific comb metallic foil configured so that radiation from both sides of the heated foil is efficiently directed out of the package along the optic axis. The foil material has a typical emissivity of 0.88 and closely emulates a black-body source in spectral distribution. The emitter is designed to operate at a rated maximum foil temperature of 1000 Kelvin. The emitter is offered in a hermetically sealed TO-5 package with integral standard parabolic reflector to provide near collimated and uniform radiation output.

Black-body Radiant Emittance

SPF Series emitters approximate black-body sources at their particular operating temperature. Below is a reference graph showing ideal black-body curves at various temperatures, in K.

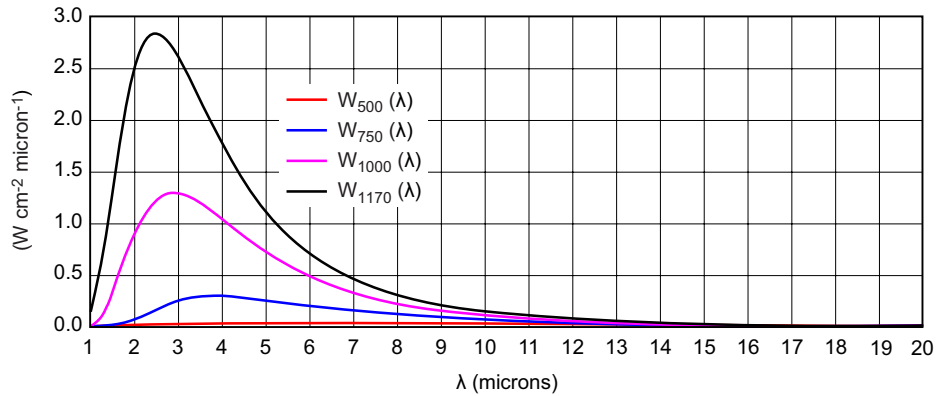

Filament Temperature vs. Input Power

The SPF pulsable emitter is designed to operate with maximum element temperatures of approximately 1000 K (727°C) at the rated input power. Since the radiated energy is proportional to the fourth power of the absolute temperature (T^4) accurate control of the input power and proper heat sinking of the package are essential to maintain consistent output. The heat sink must limit the package temperature to not more than 100°C. The relationship between peak wavelength (λ_{pk} in microns) and temperature (T in Kelvin) for the black-body spectrum is expressed by Wien's law:

$$\lambda_{pk}\ (\mu\text{m}) \times T\ (\text{K}) = 2898$$

Thus, the wavelength for maximum excitation varies inversely with the absolute temperature. For 1000 K this maximum is at 2.9 microns. The input pulse should have sufficient energy to produce a maximum filament temperature of 1000 K.

Drive Circuit

Switching device like a single N-channel MOSFET with very low on-state resistance should be used. Basic schematic is shown below.

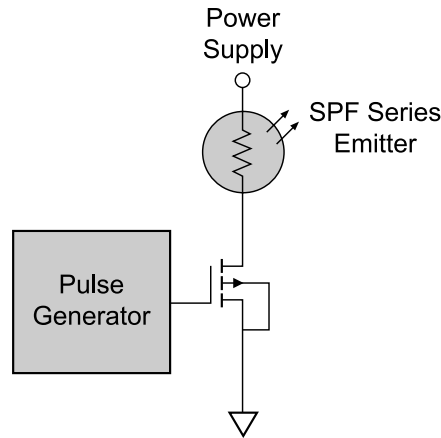

Emitter Output Optimization

The power amplitude, pulse width, and frequency are adjusted to optimize the output of the emitter. The current average current driving the source should not exceed and average current of 1 A otherwise the filament life will be degraded. Below are scope shots of two different pulse widths. The frequency and pulse amplitude of the driver are held constant and the pulse width with only been adjusted. Channel 1 is the output of the emitter measured with a PbSe detector and channel 2 is the emitter driver pulse REF monitor output from our Pire Plus Evaluation Board and Kit that is available to evaluate this high-speed SPF SPF220-5M2 emitter. Note the differences in output amplitude between the narrow and wider pulse scopes. The narrower driver pulse gives less time for the element to heat up, but it allows more time for it to cool off. The wider driver pulse gives more time for the element to heat up and less time for it to cool off. The percentage modulation depth is lower with the wider pulse than the narrower pulse, but the output intensity is much higher. This is because the element is heating up more with the wider pulse. This wider pulse makes the filament much hotter, increasing its output. In addition, the hotter filament cools off much faster, which keeps a good modulation depth resulting in a higher output swing.

The narrower pulse width (channel 1 output of emitter, channel 2 driver pulse from Pire Plus Eval Board)
 Note: that the intensity is lower but its percent modulation depth is higher.

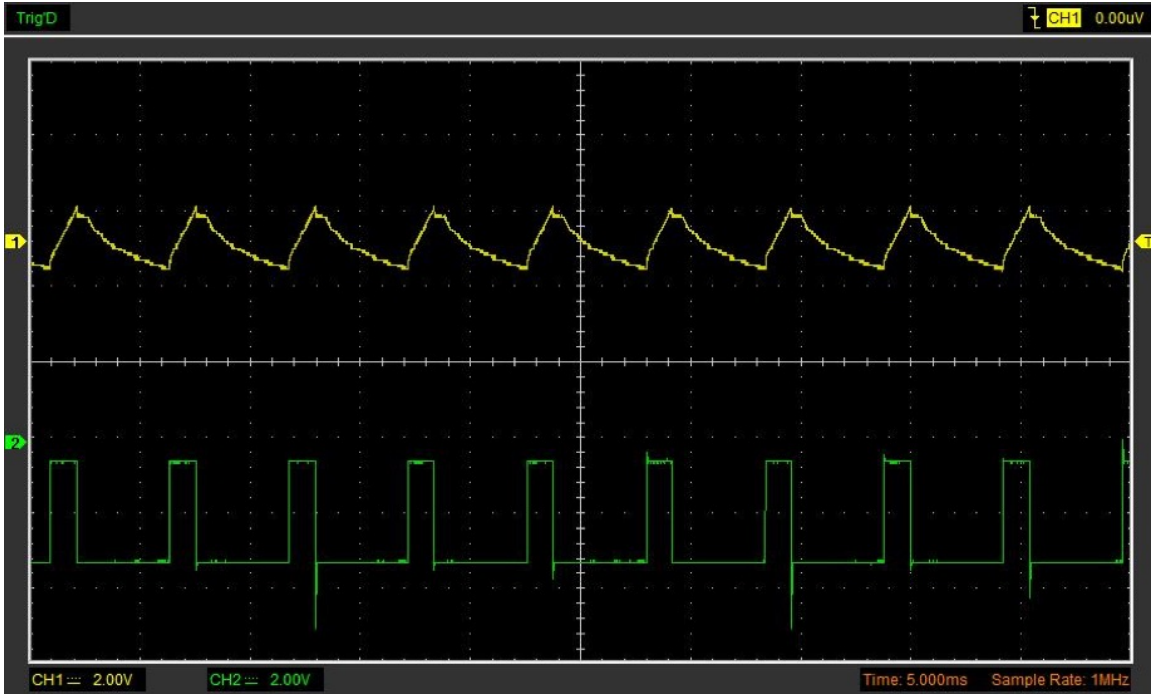

The longer pulse width (channel 1 output of the emitter, channel 2 driver pulse from Pire Plus Eval Board)
 Note: that the intensity is higher but its percent modulation depth is less.

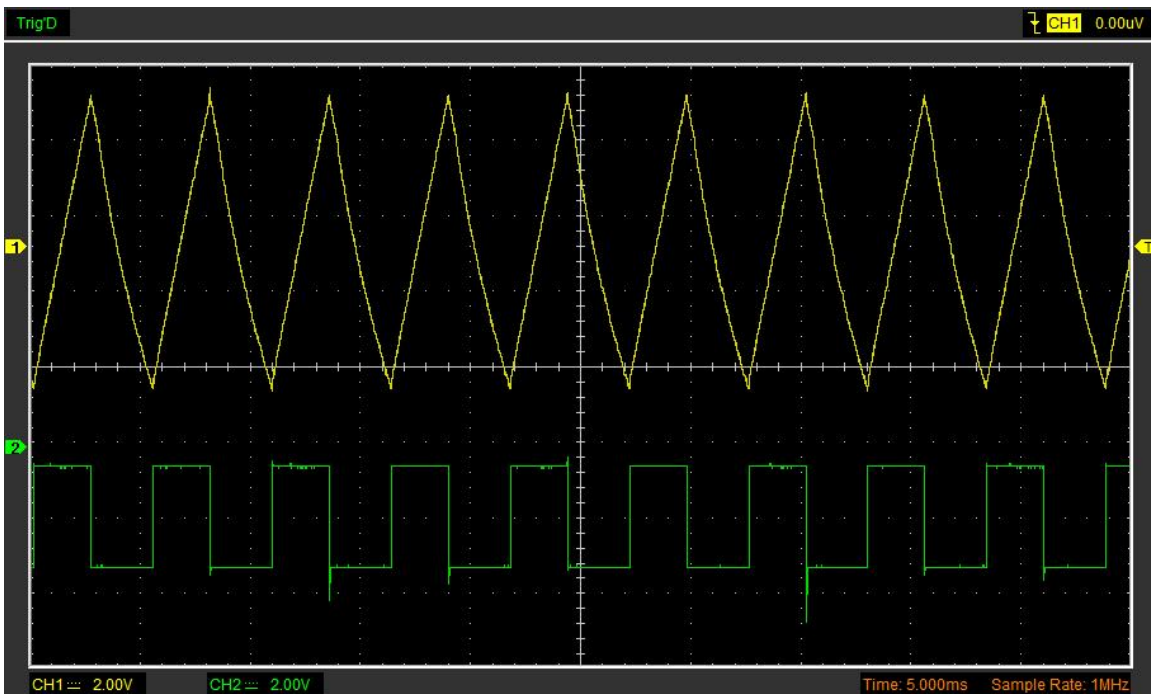

DC Power Curve (I vs V)¹

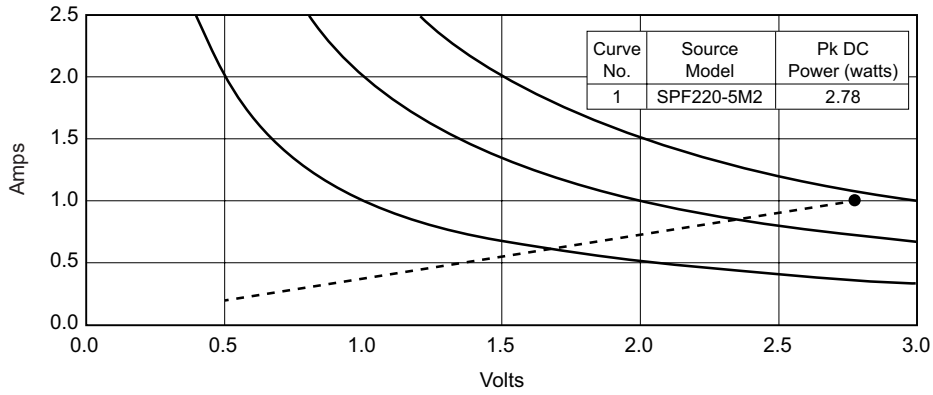

¹ 1000 K at power indicted, exceeding this value will raise element temperature and decrease source lifetime.
 Operating Temperature Range = -45° to +100°C.

Spectral Transmission of Window

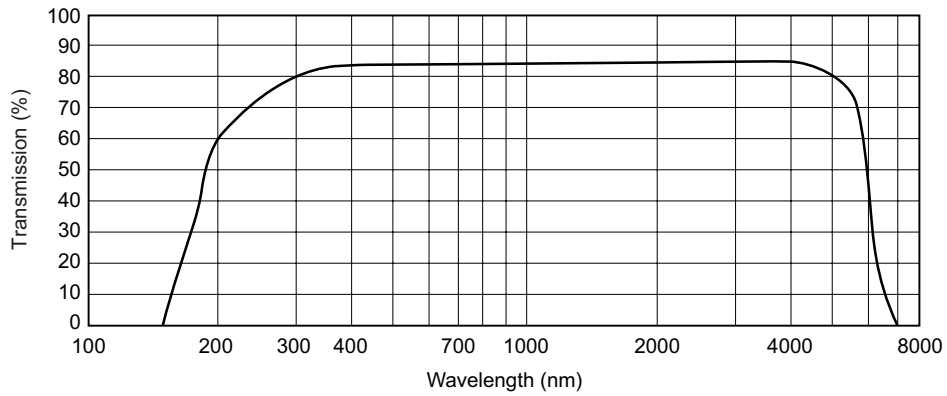

Package Dimensions

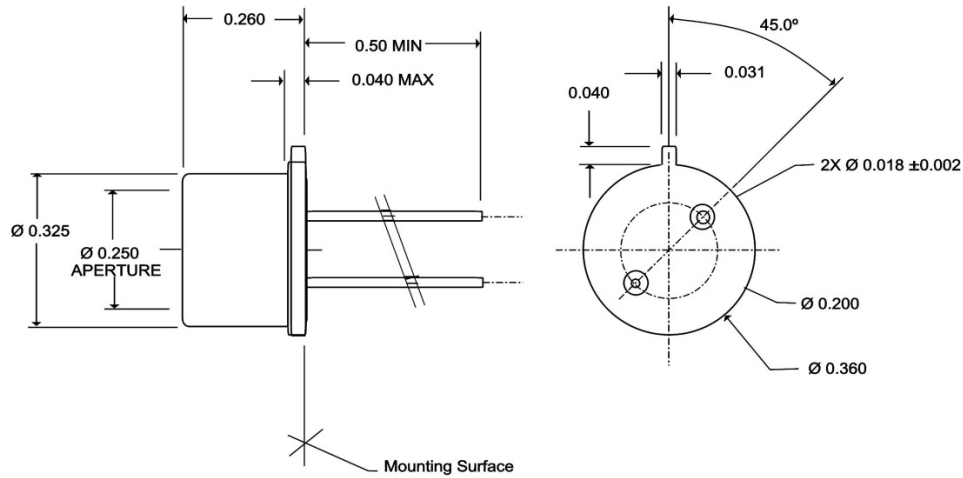

Heatsink Dimensions

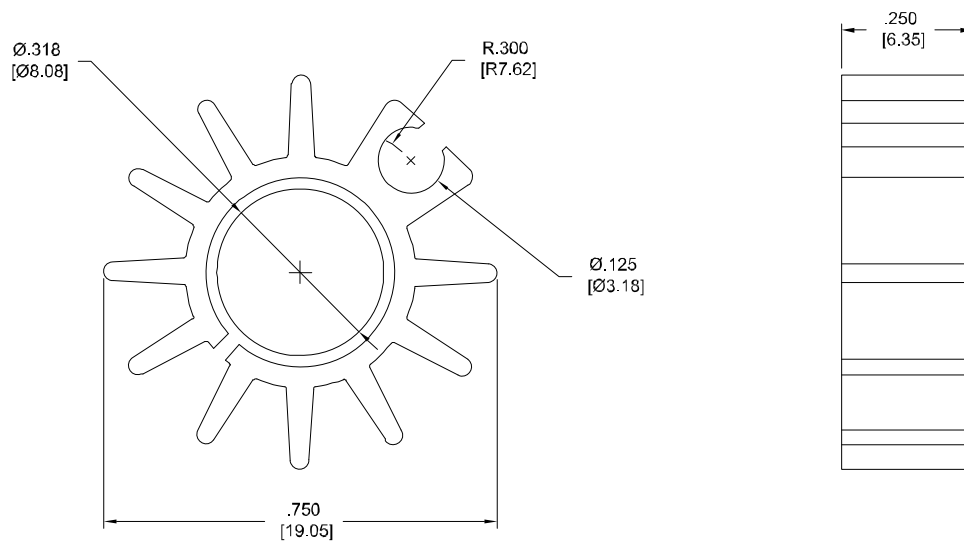

Ordering Information

High Speed Emitter in TO5 Package with Sapphire Window Model Number: SPF220-5M2 (P/N 40101)

High Speed Emitter with Heatsink Model Number: SPF220-5M2H (P/N 40800)

Evaluation Board with emitter Kit Model Number: PIRE^{PLUS} (P/N 40801)
 (Kit includes a SPF220-5M2 Emitter and heatsink)

Specifications are subject to change without prior notice.