

SA – Saturable Absorber



海纳光学有限公司

Shenzhen Highlight Optics Co., Ltd

Product Overview

- Saturable absorber for use in transmission applications
- For passive mode-locking of solid state, ring or fiber ring lasers

Phone: +0755-84870203
e-mail: sales@highlightoptics.com

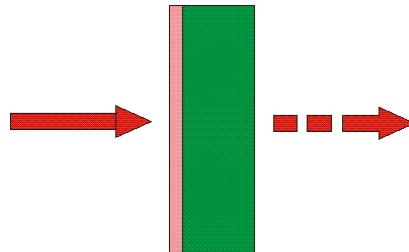

SA 1020	Laser wavelength Absorptance Relaxation time Saturation fluence	$\lambda = 980 \text{ nm} - 1040 \text{ nm}$ $A_0 = 40 \%$ $\tau \sim 500 \text{ fs}$ $\Phi_{\text{sat}} = 300 \mu\text{J}/\text{cm}^2$
SA 1064	Laser wavelength Absorptance Relaxation time Saturation fluence	$\lambda = 1030 \text{ nm} - 1090 \text{ nm}$ $A_0 = 14 - 40 \%$ $\tau \sim 500 \text{ fs} - 37 \text{ ps}$ $\Phi_{\text{sat}} = 300 \mu\text{J}/\text{cm}^2$
SA 1550	Laser wavelength Absorptance Relaxation time Saturation fluence	$\lambda = 1400 \text{ nm} - 1600 \text{ nm}$ $A_0 = 6 - 58 \%$ $\tau \sim 2 - 20 \text{ ps}$ $\Phi_{\text{sat}} = 300 \mu\text{J}/\text{cm}^2$
SA 2000	Laser wavelength Absorptance Relaxation time Saturation fluence	$\lambda = 1900 \text{ nm} - 2100 \text{ nm}$ $A_0 = 1 - 43 \%$ $\tau \sim 10 \text{ ps}$ $\Phi_{\text{sat}} = 300 \mu\text{J}/\text{cm}^2$
SA 2800	Laser wavelength Absorptance Relaxation time Saturation fluence	$\lambda = 2500 \text{ nm} - 3000 \text{ nm}$ $A_0 = 10 \%$ $\tau \sim 10 \text{ ps}$ $\Phi_{\text{sat}} = 300 \mu\text{J}/\text{cm}^2$

Mounting Options

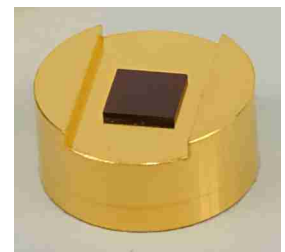

12.7 mm \varnothing - Cu-Mount with
 \varnothing 4 mm hole

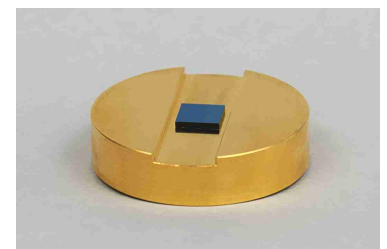

25.0 mm \varnothing - Cu-Mount with
 \varnothing 4 mm hole



Backside of 25.0 mm \varnothing - Cu-Mount
with \varnothing 4 mm hole



Fiber coupled SA

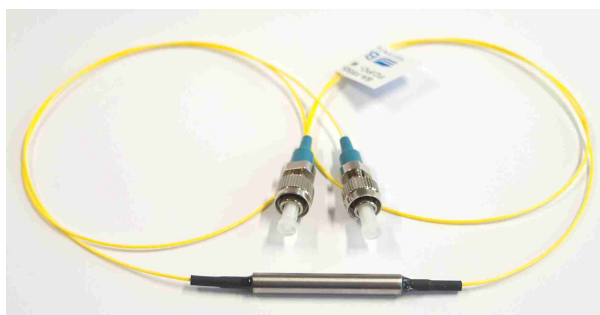

Other wavelengths and parameters on request.

- Chip area: 5 mm x 5 mm
 Chip thickness: 625 μm semi – insulating GaAs, other thickness on request
 Front side protection: AR coating
 Back side: Polished and AR coated
 Mounting:
 - Unmounted
 - Glued on:
 - 12.7 mm \varnothing Cu-mount with \varnothing 4 mm hole
 - 25.0 mm \varnothing Cu-mount with \varnothing 4 mm hole
 - Fiber coupled (SMF, PM)
 - Mounting on custom mounts on request

Cu-Mount \varnothing 12.7 mm with \varnothing 4 mm hole:

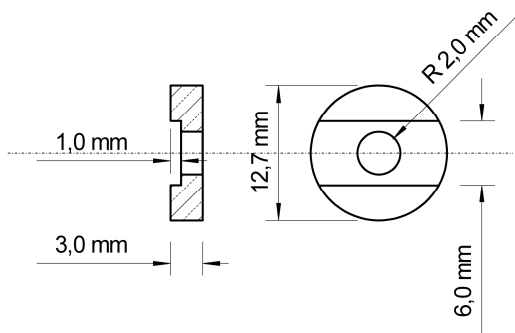

Cu-Mount \varnothing 25.0 mm with \varnothing 4 mm hole:

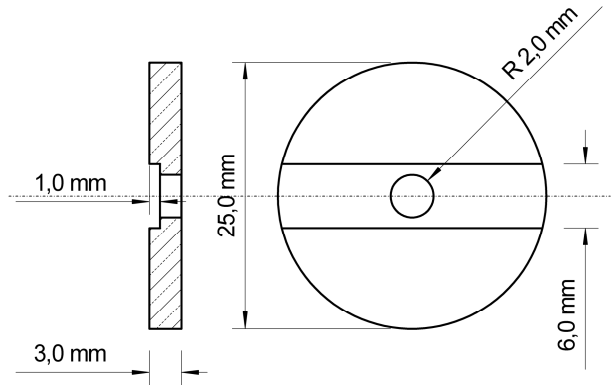

Spectral transmission / absorption:

SA 1020-40-X

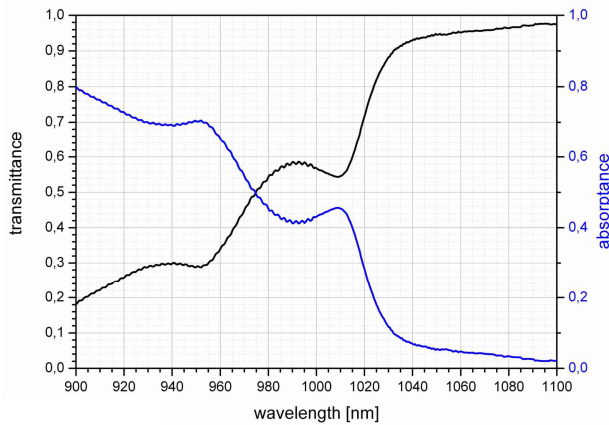

SA 1064-40-X

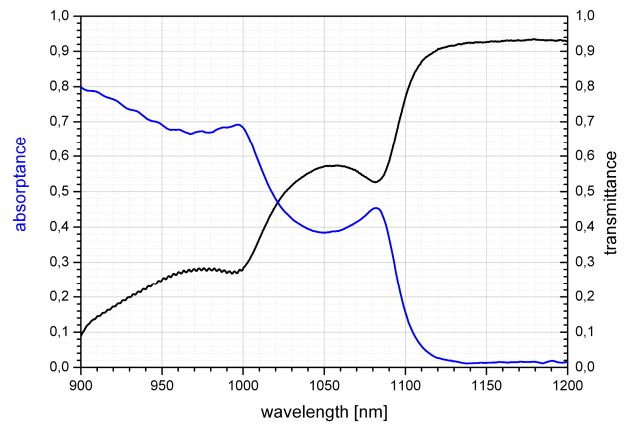

SA 1550-25-X

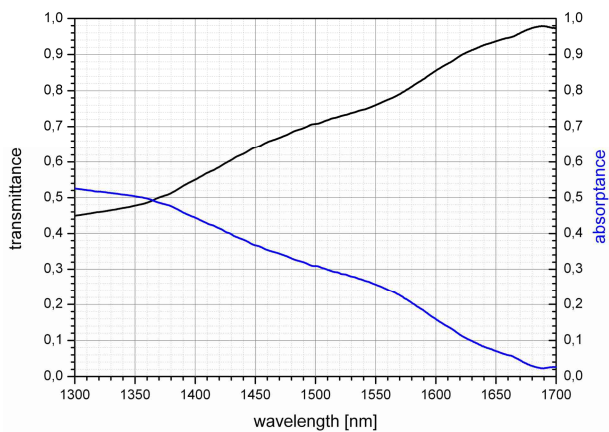

SA 2000-25-X

